

# PEDDERS

## AIR ASSIST

ADJUSTABLE AIR SUSPENSION

# FITTING INSTRUCTIONS

# 494093

INCLUDING SPECIFIC AIRBAG OPERATING HEIGHT & MAXIMUM PRESSURE

- This air suspension system is designed to assist the original vehicle manufacturer's suspension – it is not meant to carry the entire rated load. We do not recommend that leaves be removed, or other changes be made from the OEM suspension unless an applicable commercially available suspension kit is fitted.
- The kit is designed to suit a standard vehicle configuration – modifications to the vehicle outside the kit design parameters may adversely affect fitment and operation such as:
  - Height changes outside any noted in the kit specification.
  - Larger dampers (Shock Absorbers)
  - Wheel and tyre changes
  - Exhaust changes.
- If your vehicle is fitted with a brake proportioning valve or stability control system it is important to ensure this is maintained and adjusted according to the vehicle manufacturer's instructions.
- It is recommended that only a properly qualified person installs the product and carries out maintenance. If you are not qualified and attempt to carry out such work ensure that all safety equipment is used and safety standards are met.
- Ensure that you have read this full document before attempting to fit the product.
- Ensure the Product Manual is kept with the vehicle and that any vehicle owner and/or operator is fully advised on the system and its operation before attempting to drive or operate it.



SEE OTHER WARNINGS AND IMPORTANT INFORMATION IN THIS DOCUMENT

LHS = LEFT SIDE OF THE VEHICLE WHEN FACING FORWARD

### STEP 1 – PREPARE THE VEHICLE

Please note that we recommend the vehicle be un-laden when fitting this kit as you may need to create additional clearance between the axle and chassis. Ensure this is carried out according to the vehicle manufacturer's instructions.

### STEP 2 – AIRLINE TUBING & FITTINGS - GENERAL NOTES

#### CUTTING

Only cut the airline tubing with a sharp blade making the cut as square as possible.

Always trim the tubing before re-inserting into the fitting.

**⚠ If you use a sharp utility knife or razor blade great care must be taken in all cases not to cut yourself during this operation.**

#### CONNECTING & REMOVING

##### To connect:

Push the freshly trimmed tubing into the fitting as far as possible.

##### To remove:

First release the air pressure from the system. To withdraw the tubing, push and hold the collar on the fitting away from the tube and pull out the tubing.

**Hint** In confined spaces an open ended spanner can be used to evenly depress the collar and remove the airline tubing.

**CUT TUBING  
SQUARE  
WITH SHARP  
BLADE OR  
TUBE  
CUTTER**

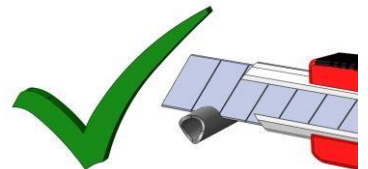

**DO NOT USE  
PLIERS, SIDE  
CUTTERS OR  
PIPE CUTTERS**

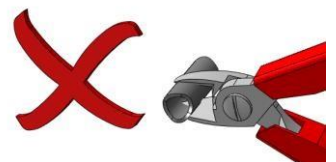

### STEP 3 – POSITION YOUR INFLATION VALVES

Select a convenient location for the air inflation valves such as the bumper or the body of the vehicle. It must be protected from road damage and be accessible for air inflation equipment.

Drill a 5/16" hole and install the air inflation valve using two 5/16" stainless steel washers as supports where required.

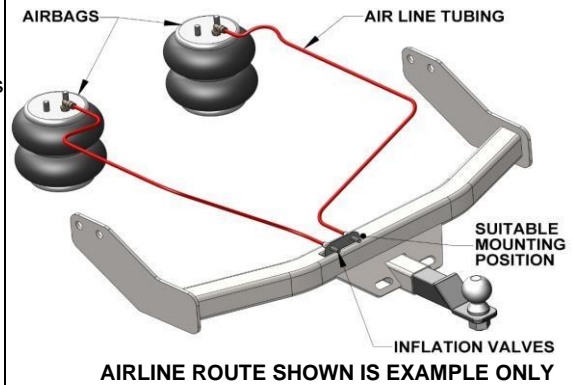
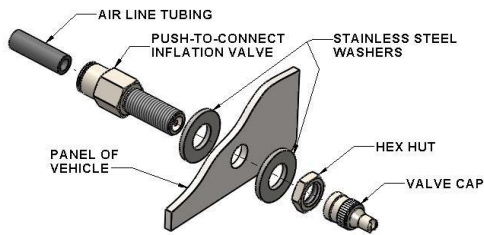

### STEP 4 - PREPARE THE AIR LINE TUBING

The air line is supplied with split protector tube pre-fitted to shield the air line during and after installation. Decide on a suitable route for the air line from the airbag to the inflation valve location to avoid direct heat from engine, exhaust pipe, and away from sharp edges.

Uncoil the air line tubing being careful not to fold or kink it and cut to length to suit the chosen route. Once routed, the protector tube is pulled back later to prepare the protected air line.

**DO NOT CONNECT OR SECURE THE AIR LINE AT THIS POINT**



### STEP 5 – REMOVE THE BUMP STOP

Release the u-bolts on the left hand side of the vehicle and remove the bump stop from the leaf. The bump stop can be discarded; leave the u-bolts loose as they will be used later to fasten the lower bracket.

### STEP 6 – INSTALL ELBOW FITTING

Install the supplied 1/4" x 1/4" elbow air fitting in the air entrance hole in the airbag. Tighten until the nylon ring contacts the air inlet, then tighten a further 1/4 turn to snug the fitting.

No additional thread sealant needed. If these fittings are re-fitted many times they will degrade their sealing ability.

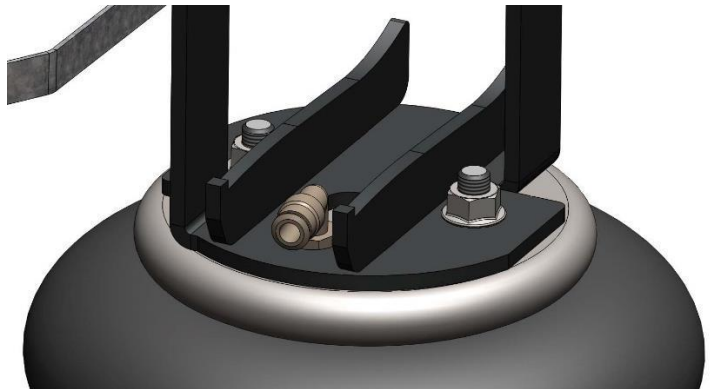

LEFT HAND SIDE SHOWN

### STEP 7 – PREASSEMBLE AIRBAG AND UPPER BRACKET

Select one airbag and an upper bracket from your kit. Ensure that the elbow air fitting is facing outwards, as in the image.

Fasten the upper bracket to the airbag using the supplied 3/8" hex flange nuts.

**NOTE:** The upper brackets are handed. RHS bracket is B2495 and LHS bracket is B2494.

The elbow fitting will be installed towards the rear of the vehicle. The short arm, with the hole in it, should be on the outboard side of the vehicle.

### STEP 8 – FIT LOWER BRACKET TO ASSEMBLY

Select one lower bracket and fasten to the airbag using two 3/8" x 3/4" UNC flange bolts provided.

**NOTE:** The bolts may be tightened once the assembly is fitted to the vehicle.

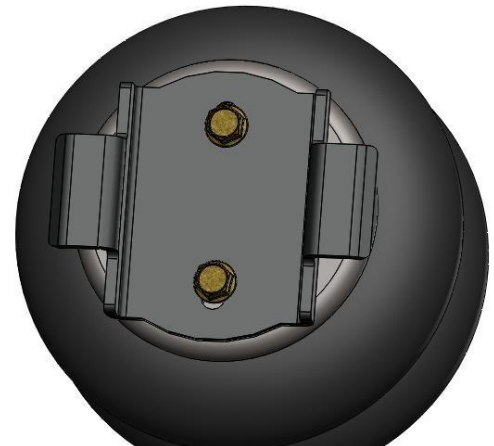

### STEP 9 – INSTALL LEFT HAND SIDE ASSEMBLY – UPPER BRACKET

The Left hand side of the vehicle has cabling running down the inboard side of the chassis. This will need to be temporarily 'popped' off the chassis to install the kit.

Connect airline tubing to the air fitting on the airbag and squash the airbag by hand. Attach other end of air line to an inflation valve to hold the airbag compressed.

The Left hand side uses the **B2494** Upper bracket. Ensure that the 'short arm' is on the outboard side of the vehicle. The elbow fitting should be facing rearward.

When installing the upper bracket, position the bracket clocked on a diagonal to increase the width between the legs while bringing it up to the chassis rail, the bracket can then be clocked back in -line with the chassis as the inner arm latches to the top edge of the chassis.

The 'long' inboard arm should wrap onto the top of the chassis. Ensure the arm slide up the chassis and pass behind any cabling.

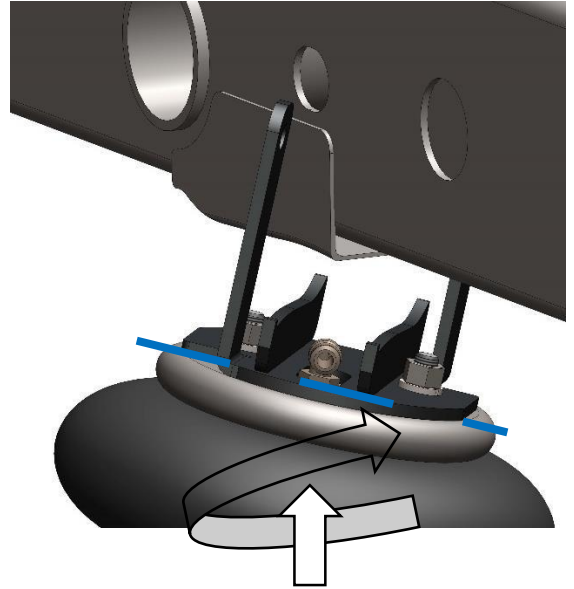
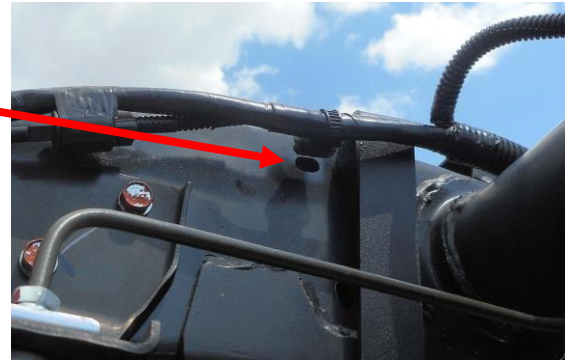
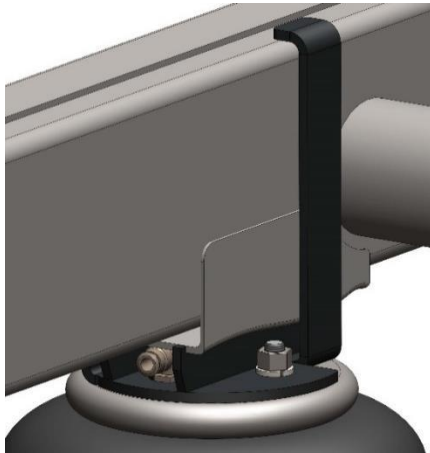

Tilt to a diagonal to assist install

**B2494 LEFT HAND SIDE -INBOARD**

The outboard 'short' arm is secured in place with the supplied tag nut. Bend the tag nut to allow alignment and install through the chassis hole to the rear, as in the image below.

Fasten the bracket through the hole using the nut tag and supplied 3/8" x 1 1/4" bolt, spring washer and flat washer, in to the tag nut.

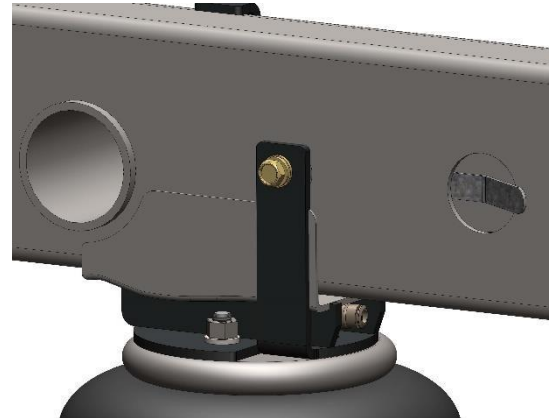
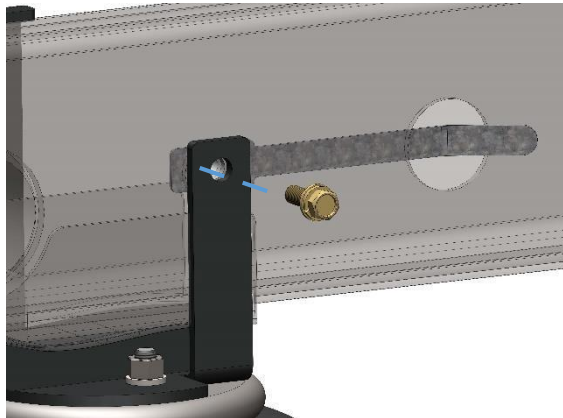

### STEP 10 – SECURE THE LOWER BRACKET

Release the tubing from the inflation valve to expand the airbag and position the lower bracket under the u-bolts on the leaf spring, aligning the bracket in the same position the jounce bumper was in.

**Tighten the u -bolt nuts to the manufacturers recommended torque setting.**

Set the alignment of the airbag to the best position then tighten the lower airbag bolts.

**Re-connect the original cabling that was loosened in Step 9 into position.**



### STEP 11 – INSTALL THE RIGHT HAND ASSEMBLY

Follow Steps 5 - 10 for the right hand side of the vehicle, reversing any orientations. Ensure that the **B2495** bracket is used for the right hand side assembly.

### STEP 12 – CONNECT AIRLINE TUBING

Route airline tubing and connect to airbag air fittings and inflation valves. Secure with supplied nylon ties.  
Check the tubing to ensure it is not angled where it enters an air fitting, as side loads on the fitting may cause a leak.

### STEP 13 – LEAK TEST

**INFLATE** the airbag to the maximum allowed pressure (See Specific Operating Pressure Advice) and check for leaks at the connections using soapy water spray. We recommend a soapy water spray solution of 25% soap to 75% water.

**DEFLATE** airbag. If no leaks, continue. If leak detected, check and tighten the airbag fittings (if required), remove the airline tubing, recut and re-test.

### STEP 14 – FITMENT COMPLETION

Now tighten up the sway bar bolts and reattach all suspension components removed earlier and return the vehicle to driving position. Ensure this operation is carried out according to the vehicle manufacturer's instructions.

### STEP 15 – AIRBAG HEIGHT AND ALIGNMENT

The airbag must be checked for the correct installed height, vertical alignment and clearances with the vehicle leveled out.

**INFLATE** the airbags until a level vehicle height is reached and measure the bag height between the mounting plates.

The AB0136 airbag in this kit requires a height of 5.5" to 6.5" to be maintained under all loads.

It is important to ensure that the airbag does not make contact with any other components in all load and height conditions.

**If the centreline of the airbag end plates are misaligned in any direction more than the amount shown to the right, please contact Pedders for further technical support.**

Please note: Misalignment and angled installation at ride height is often required to ensure correct alignment through the suspension travel.

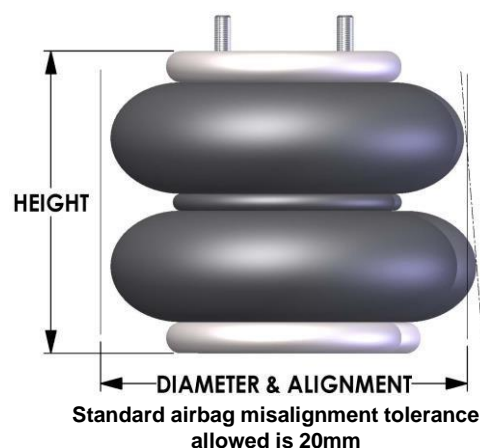

### STEP 16 – TO FINISH

Stick the supplied warning decal in a prominent position in sight of the vehicle operator.

Ensure the vehicle owner/operator fully understands how to use the product. All fixings should be checked for tightness after the first laden run and thereafter as per the original manufacturer's recommendations



## **AIRBAG OPERATING HEIGHT & MAXIMUM PRESSURE**

See operating instructions section for proper use and maintain the specific height below:

### **OPERATING HEIGHT**

The **AB0136** airbag in this kit requires a height of **5.5" to 6.5"** under all loads.  
Adjust and retain pressure up to the stated maximum to maintain the airbag operating height. Failure to do so may result in product or vehicle damage not covered under warranty.

### **MAXIMUM PRESSURE**

**40 PSI (2.75 bar)**

**IF MORE PRESSURE IS REQUIRED TO MAINTAIN THE OPERATING HEIGHT CALL YOUR  
NEAREST PEDDERS OUTLET FOR FURTHER TECHNICAL ADVICE**

**Incorrect use of this air suspension product can result in damage to the airbag, associated parts and/or the vehicle, which is not covered under warranty.**

**Ensure the airbags are maintained at the stated ride height at all times and the maximum pressure is never exceeded.**